

**RACENT**



**CLAYMORE  
CLAYMORE  
SPEED BOAT  
SERIES**

# WARNING

The following terms are used throughout the product literature to indicate various levels of potential harm when operating this product:

**NOTICE:** Procedures, which if not be properly followed, will create a possibility of physical property damage AND or possibility of injury.

**WARNING:** Read the **ENTIRE** instruction manual to become familiar with the features of the product before operating. Fail to operate the product correctly can result in damage to the product, personal property and cause serious injury.

This is a sophisticated hobby product. It must be operated with caution and common sense and requires some basic mechanical ability. Fail to operate this product in a safe and responsible manner could result in injury or damage to the product or other property. This product is not intended for use by children without direct adult supervision. Do not use with incompatible components or alter this product in any way outside of the instructions provided by VolantexRC Co.,Ltd.. This manual contains instructions for safety, operation and maintenance. It is essential to read and follow all the instructions and warnings in the manual, prior to assembly, setup or use, in order to operate correctly and avoid damage or serious injury.

**AGE RECOMMENDATION: NOT FOR CHILDREN UNDER 14 YEARS. THIS IS NOT A TOY.**

## Safety Precautions and Warnings

As the user of this product, you are solely responsible for operating in a manner that does not endanger yourself and others or result in damage to the product or the property of others.

- Always keep a safe distance in all directions around your model to avoid collisions or injury. This model is controlled by a radio signal subject to interference from many sources outside your control. Interference can cause momentary loss of control.
- Always operate your model in open spaces away from full-size vehicles, traffic and people.
- Always carefully follow the directions and warnings for this and any optional support equipment(chargers, rechargeable battery packs etc.).
- Always keep all chemicals, small parts and anything electrical out of the reach of children.
- Always avoid water exposure to all equipment not specially designed and protected for this purpose. Moisture causes damage to electronics.

- Never place any portion of the model in your mouth as it could cause serious injury or even death.
- Never operate your model with low transmitter batteries.
- Always keep your model in sight and under control.
- Always use fully charged batteries.
- Always keep transmitter powered on while model is powered.
- Always remove batteries before disassembly.
- Always keep moving parts clean.
- Always keep parts dry.
- Always let parts cool after using before touching.
- Always remove batteries after usage.
- Always ensure failsafe is properly set before running.
- Never operate a model with damaged wiring.

## Charging Warnings

The battery charger included with your model(if there be) is designed to safely balance and charge the Li-Po/Li-Ion/Ni-Mh battery.

**CAUTION:** All instructions and warnings must be followed exactly. Mishandling of Li-Po/Li-Ion/Ni-Mh batteries can result in fire, personal injury, and/or property damage.

- By handling, charging or using the included battery, you shall assume all risks associated with Li-Po/Li-Ion/Ni-Mh battery.
  - If at any time the battery begins to balloon or swell, discontinue use immediately. If charging or discharging, you should discontinue and disconnect. Continue to use, charge or discharge a battery that is ballooning or swelling can result in fire.
  - Always store the battery at room temperature in a dry area for best results.
  - Always transport or temporarily store the battery in a temperature range of 40-120 Fahrenheit degrees (5-49 degrees centigrade).
- Do not store battery or your model in a car or direct sunlight. If stored in a hot car, the battery can be damaged or even cause fire.
- Always charge a battery away from flammable materials.
  - Always inspect the battery before charging and never charge damaged batteries.

- Always disconnect the battery after charging, and allow the charger cool before next charge.
  - Always constantly monitor the temperature of the battery pack while charging.
  - **ONLY USE A CHARGER SPECIALLY DESIGNED TO CHARGE SPECIFIC BATTERIES.**
- Fail to charge a battery with a compatible charger may cause fire resulting in personal injury and or property damage.
- Never discharge Li-Po cells till below 3V under load.
  - Never cover warning labels with hook or loop strips.
  - Never leave charging batteries unattended.
  - Never charge batteries outside recommended levels.
  - Never attempt to dismantle or alter the charger.
  - Never allow minors to charge battery packs.
  - Never charge batteries in extremely hot or cold places(recommended between 40-120 Fahrenheit degrees / 5-49 degrees centigrade) or in direct sunlight.

## Battery(Li-Po) Safety Precautions

### IMPORTANT NOTE:

Lithium Polymer(Li-Po) batteries are significantly more volatile than alkaline, Ni-Cd or Ni-Mh batteries used in RC applications. All instructions and warnings must be followed exactly to prevent property damage and/or personal injury as mishandling of Li-Po batteries can result in fire. By handling, charging or using the included Li-Po battery, you assume all risks associated with Li-Po batteries. If you do not agree with these conditions, please return your complete product in new, unused condition to the place of purchase immediately. You must read the following safety instructions and warnings before handling, charging or using Li-Po battery.

## Boat Battery Pack(s) Installation

1. Rotate the hatch on the hull cover in clockwise to unlock the hatch.
2. Open the hull cover.
3. Adhere loop tape(included) to the battery.
4. Secure the battery in the hull with the hook and loop.
5. Secure the battery in the hull with the hook and loop strap as shown.

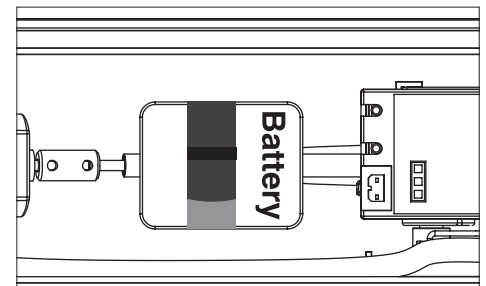
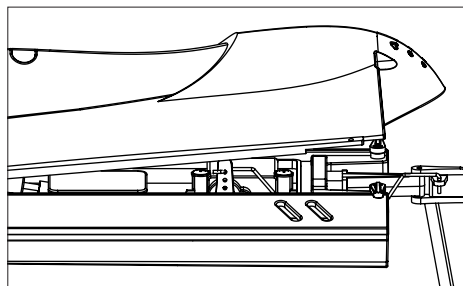
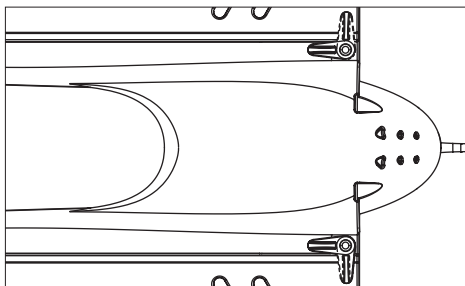

## Check Radio System

**CAUTION:** Always keep all body parts, hair and dangling or loose items away from a spinning propeller, as these can be entangled.

**NOTICE:** Always power on the transmitter before powering on the ESC. Always power off the ESC before powering off the transmitter. Never transport the model with the battery connected to the ESC.

1. Turn the transmitter throttle and rudder trim to the middle position.
2. Power on the transmitter.
3. Connect a fully charged battery to the ESC.
4. Ensure the rudder moves in the proper direction when the controller is moved left or right.
5. Pull the throttle to max power position, then return the throttle to min power position, ensuring the propeller turns counterclockwise. The ESC auto-sensing voltage cutoff function will engage when the ESC detects a low battery charge. Release the throttle and recharge the battery when necessary.

**NOTICE:** Read completely the radio appendix for more detailed instruction of using the radio. Make sure you have totally studied the radio manual appendix before you really start operating the model with the radio.

## Getting Started

1. Power on the transmitter.
2. Connect a fully charged battery.
3. Test the transmitter's control of the boat with the boat on the display stand.
4. After launching the boat in the water, start driving slowly. If the boat does not go straight, adjust the trimmer on the transmitter to run it straight.
5. Power off the ESC and disconnect the battery packs.
6. Always turn off transmitter at last.
7. Allow the motor, ESC and battery packs to cool before charging the battery or operating the boat again.

**WARNING:** DO NOT TURN OFF THE TRANSMITTER BEFORE UNCONNECTING BATTERY OF RECEIVER, OR THE RECEIVER MAY PICK UP STRAY SIGNALS AND RUN OUT OF CONTROL TO CAUSE ACCIDENT!

**NOTICE:** Always store the boat with hatch removed to prevent mold and mildew growth inside the hull.

## Test Your Boat in Water

1. Carefully place the boat in water.
2. Operate the boat at slow speed near the shoreline. Avoid objects in water at all time.
3. Once you are comfortable operating the boat at slow speed, make sure it is safe and then operate the boat farther from the shoreside.

Tip: If you are using too much steering trim on your transmitter to make the boat drive straight, return the trim to neutral and mechanically center the rudder. To do this, loosen the knob from the rudder horn, adjust the knob to a proper position linking to pushrod, make sure ruder is centered.

4. Bring the boat back when you notice it starts to run at low speed even when you pull up throttle to max.

## Tips of Controlling

Keep away from watercraft, stationary objects, waves and other rapidly moving water, wildlife, floating debris or overhanging trees. You should be so careful to avoid boating in areas where there are many people, such as swimming areas, park waterways or fishing areas. Consult local laws and ordinances before choosing a location to pilot your boat. Maximum speeds are only achieved when the water conditions are smooth and there is little wind. A sharp turn, wind or waves can turn over a boat when it is moving quickly. Always control your boat for the wind and water conditions so that the boat does not turn over. When running your boat for the first time, we recommend calm wind and water conditions so that you can learn how the boat responds to your control. When making turns, decrease the throttle in order to decrease speed and probability of flipping the boat over.

**NOTICE:** When running at full speed in choppy waters, the propeller may exit and re-enter the water repeatedly and very quickly, subjecting the propeller to some stress. Frequent stress may damage the propeller.

**CAUTION:** Never retrieve your boat from the water in extreme temperatures, turbulence or without supervision.

## Motor Care

Prolong motor life by preventing overheating conditions. Undue motor wear results from frequent turns, stops and starts, pushing object, boating in rough or vegetation and boating continuously at high speed. Over-temperature protection is installed on the ESC to prevent circuit damage, but cannot protect the motor from pushing against heavy resistance.

## When You Finish

1. Power off the ESC.
2. Disconnect the battery in hull.
3. Power off the transmitter.
4. Remove batteries from boat and transmitter.

**NOTICE:** Always store the boat without hatch covered or inner liner sealed. Otherwise moisture may cause mold and mildew to grow in the boat.

## Maintenance

Always replace the shaft when it is damaged or shows visible wear or injury and property damage may result.

Lubricating the shaft is vital to the life of the drivetrain. The lubricant also acts as a water seal, keeping water from entering the hull through the stuffing box.

Lubricate the shaft, propeller shaft and all moving parts after every 2-3 hours of operation. Always replace parts that show visible wear or damage.

1. Loosen the coupling between the motor and the shaft.

2. Loosen setscrew from the shaft and remove the shaft from the back of the boat.  
Tips: Use paper or cloth to touch the shaft.

3. Remove the drive shaft by sliding it out of the stuffing box. Wipe lubricant and material from the shaft. Lubricate the full length of the shaft assembly up the drive dog with marine grease.

4. Apply threadlock to the coupling setscrew. Threadlock will help prevent the shaft from loosening during usage.

5. Carefully reinstall the drive shaft, ensuring that there is a 1-2mm gap between the prop strut and the drive dog to allow for shaft shrinkage under load.

NOTICE: Running the boat in salt water could cause some parts to corrode. If you run the boat in salt water, rinse it thoroughly in fresh water after each use and lubricate the drive system.

NOTICE: Because of its corrosive effects, running RC boats in salt water is at the discretion of the user.

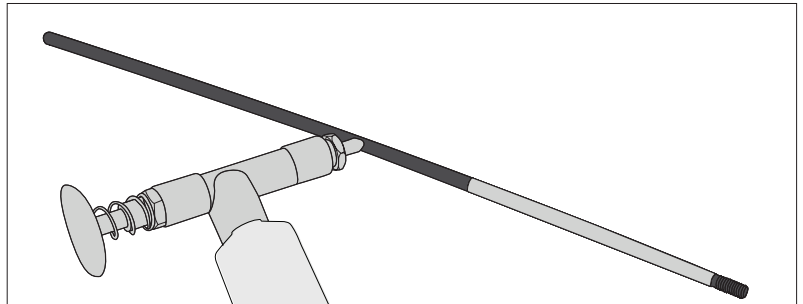
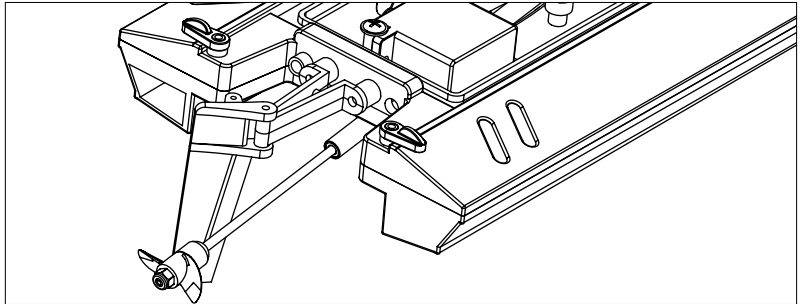
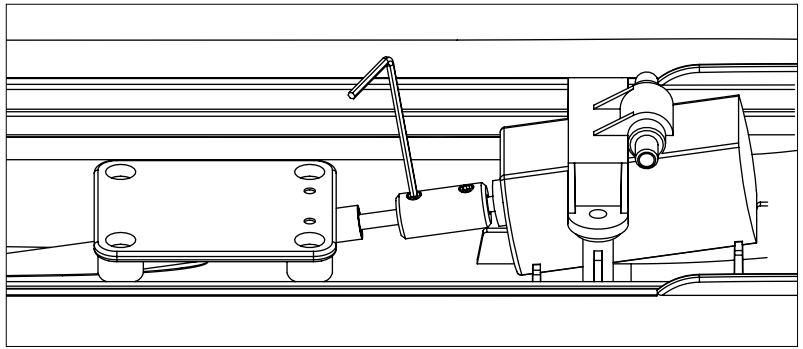

## Check List

### Before Boating

- Install fully charged batteries in your boat and transmitter.
- Connect the boat battery to ESC.
- Make sure the boat is bound to the transmitter (otherwise, bind the boat to the transmitter using the included binding instructions.)
- Make sure all linkages move freely on the boat.
- Ensure the motor mount is secured to the hull so that the motor stays steady.
- Perform a Control Direction Test with the transmitter.
- Adjust the steering rate on your transmitter as needed.
- Find a safe and open boating area.
- Plan a safe boating route for the water and wind conditions.

### After Boating

- Always power off the receiver before powering off the transmitter to maintain control of the boat and to retain transmitter binding.
  - Disconnect the battery from the receiver and remove the batteries from the boat.
  - Fully dry the inside and outside of the boat, including the water cooling lines and jackets around the motor and ESC. Remove the hatch and radio box cover before storing your boat.
  - Repair any damage or wear to the boat.
  - Lubricate the shaft.
  - Make note of lessons learned from the trimming of your boat, including water and wind conditions.
- Tips: The hook and look strips in the boat retain water. To dry them press on them with a dry cloth.

# Troubleshooting Guide

Problem	Possible Cause	Solution
Boat does not respond to throttle but responds to other controls	Throttle servo travel is lower than 100%	Make sure throttle servo travel is 100% or greater
	Throttle channel is reversed	Reverse throttle channel on transmitter
Extra noise or extra vibration	Damaged propeller, shaft or motor	Replace damaged parts
	Propeller is out of balance	Balance or replace propeller
Reduced runtime or boat underpowered	Boat battery charge is low	Completely recharge battery
	Boat battery is damaged	Replace boat battery and follow battery instructions
	Blocking or friction on shaft or propeller	Disassemble, lubricate and correctly align parts
	Boat conditions may be too cold	Make sure battery is warm before use
	Battery capacity may be too low for conditions	Replace battery or use a larger capacity battery
	Drive dog is too close	Loosen coupling at shaft and move away shaft a small amount
	Too little lubrication on shaft	Fully lubricate shaft
	Vegetation or other obstacles block the rudder or propeller	Remove boat from the water and obstacles
Boat does not bind (during binding) to transmitter	Transmitter is too near boat during binding process	Move powered transmitter a few feet from boat, disconnect and reconnect battery to boat
	Boat or transmitter is too close to large metal object	Move boat or transmitter away from large metal object
	Bind plug is not installed correctly	Install bind plug and bind boat to transmitter
	Boat battery/ Transmitter battery charge is too low	Replace/recharge batteries
	ESC switch is off	Power on ESC switch
Boat does not link (after binding) to transmitter	Transmitter is too near boat during linking process	Move powered transmitter a few feet from boat, disconnect and reconnect battery to boat
	Boat or transmitter is too close to large metal object	Move boat or transmitter away from large metal object
	Bind plug is left installed	Rebind transmitter to boat and remove bind plug before cycling power
	Boat battery/transmitter battery charge is too low	Replace/recharge batteries
	Transmitter may have been bound to a different model (using different DSM Protocol)	Bind boat to transmitter
	ESC switch is off	Power on ESC switch
Boat tends to dive in water or takes on water	The boat hull is not completely closed	Dry out the boat and ensure the hatch is fully closed on the hull before re turning the boat to the water
	Center of gravity is too far forward	Move batteries back in the hull
	Trim tabs are angled incorrectly on the back of the boat	Angle each trim tab up a small amount to lift the bow or down a small amount to lower the bow

Boat tends to turn one direction	Rudder or rudder trim is not centered	Repair rudder or adjust rudder and rudder trim for straight running when control is at neutral
	Vertical fins of trim tabs are angled incorrectly	Angle the fins a small amount right or left so that the boat goes straight when the rudder is at neutral
Rudder does not move	Rudder, linkage or servo damage	Replace or repair damaged parts and adjust controls
	Wire is damaged or connections are loose	Do a check of wires and connections, connect or replace as needed
	Transmitter is not bound correctly or the incorrect model was selected	Rebind or select correct model in transmitter
	BEC (Battery Elimination Circuit) of the ESC is damaged	Replace ESC
	ESC switch is off	Power on ESC switch
Controls reversed	Transmitter settings are reversed	Do the Control Direction Test and adjust controls on transmitter appropriately
Motor or ESC overheats	Blocked water cooler tubes	Clean or replace water tubes
Motor power pulses then motor loses power	ESC uses default soft Low Voltage Cut off (LVC)	Recharge boat battery or replace battery that is no longer performing
	Weather conditions might be too cold	Postpone until weather is warmer
	Battery is old, worn out or damaged	Replace battery
	Battery Crating might be too small	Use recommended battery
Boat does not link (after binding) to transmitter	Transmitter is too near boat during linking process	Move powered transmitter a few feet from boat, disconnect and reconnect battery to boat
	Boat or transmitter is too close to large metal object	Move boat or transmitter away from large metal object
	Bind plug is left installed	Rebind transmitter to boat and remove bind plug before cycling power
	Boat battery/transmitter battery charge is too low	Replace/recharge batteries
	Transmitter may have been bound to a different model (using different DSM Protocol)	Bind boat to transmitter
	ESC switch is off	Power on ESC switch

# VOLANTEX RC

© 2015 VOLANTEXRC Co.,Ltd.